

30x30 corner extrusion type B02-3

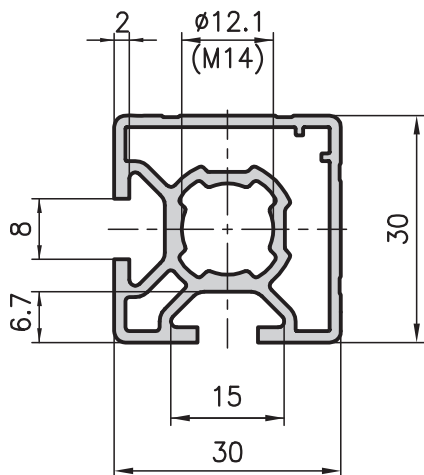

30x30 corner extrusion with panel slots type B01-3

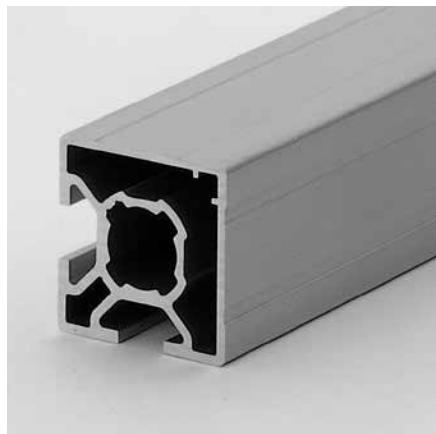
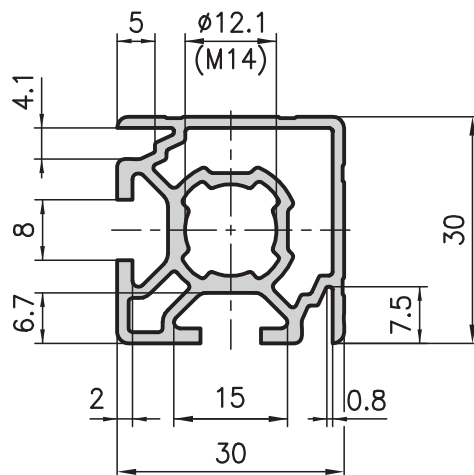

Application

Workstation design, enclosures, apparatus trolleys and more lightweight structures. This corner profile looks extremely compact because it is closed on two sides and is the natural choice in any application where only two slots are required for joining components together. Metal and/or composite panels are easy to fit as enclosure elements thanks to the additional panel slots.

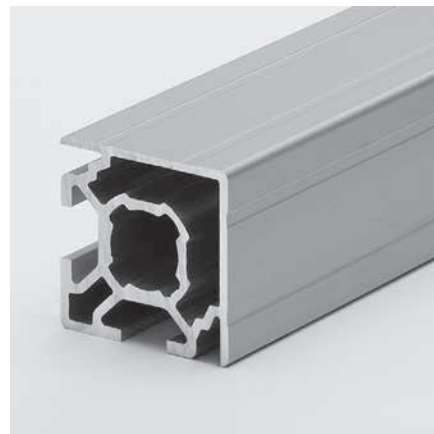

Technical data

$I_{x,y}$	=	2.70 cm ⁴
$W_{x,y}$	=	1.75 cm ³
Cross-section area	=	2.95 cm ²
Weight	=	0.8 kg/m

Order data

Order number

30x30 corner extrusion	
Standard length 5000 mm	B02-3-00/5000
30x30 corner extrusion	
Cut to length	B02-3-02-02/...
Extra machining	Pages 57-61



Technical data

$I_{x,y}$	=	2.70 cm ⁴
$W_{x,y}$	=	1.75 cm ³
Cross-section area	=	2.98 cm ²
Weight	=	0.8 kg/m

Order data

Order number

30x30 corner enclosure extrusion	
Standard length 5000 mm	B01-3-00/5000
30x30 corner enclosure extrusion	
Cut to length	B01-3-02-02/...
Extra machining	Pages 57-61